

SZA***A Series

GLASS PASSIVATED JUNCTION Zener voltage regulator diodes 1.0 Watt Steady State

Feature

- * 1W SMA
- * Zener voltage regulator diodes
- * Plastic package has Underwriters Laboratory Flammability Classification 94V-0
- * We declare that the material of product compliance with RoHS requirements.
- * Guarding for over voltage protection
- * High temperature soldering guaranteed: 260°C/10 seconds at terminals



Mechanical Data

Case: JEDEC DO-214AC molded plastic

Terminals: Axial leads, solderable per MIL-STD-202, Method 208

Polarity: Color band denoted cathode except Bipolar

Mounting Position: Any

Weight: 0.0023 ounce, 0.065 gram

1. Electrical Characteristic

Ratings at 25°C ambient temperature unless otherwise specified.

Single phase, half wave, 60Hz, resistive or inductive load.

For capacitive load, derate current by 20%.

RATING	SYMBOL	VALUE	UNITS
Steady State Power Dissipation at $T_L=75^\circ\text{C}$ (Note1)	$P_{M(AV)}$	1.0	Watts
Z-current	I_Z	P_V/V_Z	mA
Peak Forward Surge Current, 8.3ms Single Half Sine-Wave Superimposed on Rated Load(JECED Method) (Note 2)	I_{FSM}	40	Amps
Operating and Storage Temperature Range	T_J, T_{STG}	-50 to +150	°C

NOTES:

1. Mounted on Copper Leaf area of 1.57in²(40mm²).
2. 8.3ms single half sine-wave, duty cycle= 4 pulses per minutes maximum.

We declare that the material of product compliance with ROHS requirements

SZA***A Series

2.Product Characteristic

Vz tolerance : ±5%; Ta=25°C Vfmax =1.2V @ IF = 200mA P=1 W

Type	Device marking code	Zener	Current	A and B Suffix only			Leakage Current		Surge current	Maximum Regulator Current(2)
		Voltage	Izt	Zzt @ Izt	Zzk @ Izk	Zzk @ Izk	IR	VR	IR @ Tamb = 25 °C	IzM @ Tamb =50 ° C
		<u>Vz@Izt</u>								
		Volts	mA	Ohms	Ohms	m A	uA Max	Volts	mA	mA
SZA6.8A	Z6.8A	6.8	37	4	1300	1	100	4	660	133
SZA7.5A	Z7.5A	7.5	34	4.5	1300	0.5		5	605	121
SZA8.2A	Z8.2A	8.2	31	5.5	1300	0.5		6	550	110
SZA9.1A	Z9.1A	9.1	28	6	1300	0.5		7	500	100
SZA10A	Z10A	10	25	7	1300	0.25	20	7.6	454	91
SZA11A	Z11A	11	23	8	1300			8.4	414	83
SZA12A	Z12A	12	21	9	1300			9.1	380	76
SZA13A	Z13A	13	19	10	1300			9.9	344	69
SZA15A	Z15A	15	17	14	1300			11.4	304	61
SZA16A	Z16A	16	15.5	16	1300			12.2	285	57
SZA18A	Z18A	18	14	20	1300			13.7	250	50
SZA20A	Z20A	20	12.5	22	1300			15.2	225	45
SZA22A	Z22A	22	11.5	23	1300			16.7	205	41
SZA24A	Z24A	24	10.5	25	1300			18.2	190	38
SZA27A	Z27A	27	9.5	35	1300			20.6	170	34
SZA30A	Z30A	30	8.5	40	1500			22.8	150	30
SZA33A	Z33A	33	7.5	45	1500			25.1	135	27
SZA36A	Z36A	36	7	50	1500			27.4	125	25
SZA39A	Z39A	39	6.5	60	1500			29.7	115	23
SZA43A	Z43A	43	6	70	2500			32.7	110	22
SZA47A	Z47A	47	5.5	80	2500	35.8	95	19		
SZA51A	Z51A	51	5	95	2500	38.8	90	18		
SZA56A	Z56A	56	4.5	110	2500	42.6	80	16		
SZA62A	Z62A	62	4	125	2500	47.1	70	14		
SZA68A	Z68A	68	3.7	150	2500	51.7	65	13		
SZA75A	Z75A	75	3.3	175	2500	56	60	12		
SZA82A	Z82A	82	3	200	3000	62.2	55	11		
SZA91A	Z91A	91	2.8	250	3000	69.2	50	10		
SZA100A	Z100A	100	2.5	350	3000	76	45	9		
SZA110A	Z110A	110	2	550	5000	83	42	8		
SZA120A	Z120A	120	1.5	750	5500	90	38	7		
SZA130A	Z130A	130	1	900	6000	98	34	6		
SZA150A	Z150A	150	1	1200	6500	113	30	6		
SZA160A	Z160A	160	1	1350	7000	120	28	6		
SZA180A	Z180A	180	1	1650	8500	135	25	5		
SZA200A	Z200A	200	1	1950	10000	150	23	4		

SZA***A Series

3.Characteristic Curves

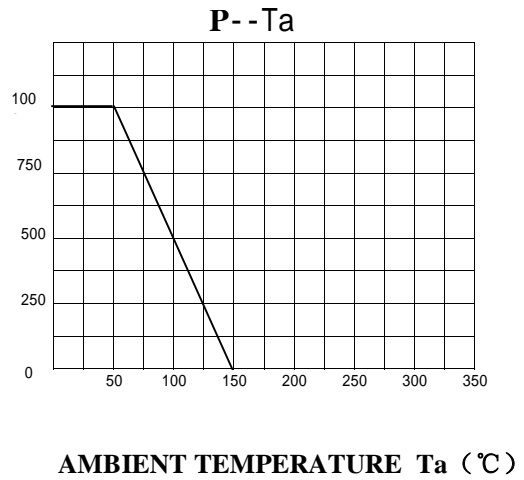
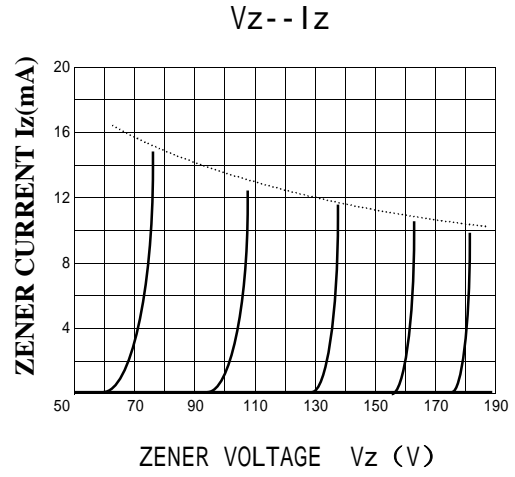
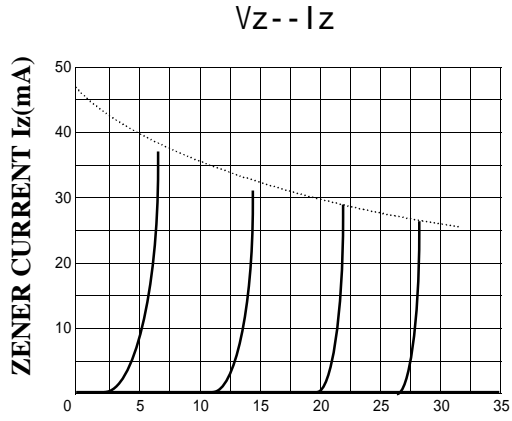

SZA***A Series

4.Package Dimensions in inches and (millimeters)

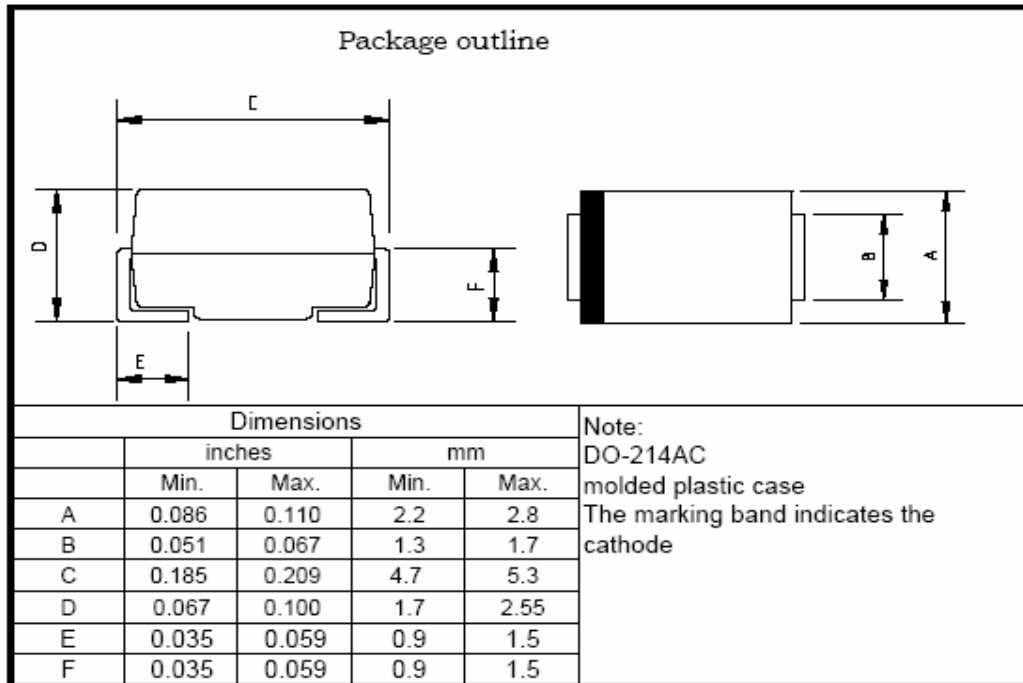

Mounting Pad Layout

---SMA

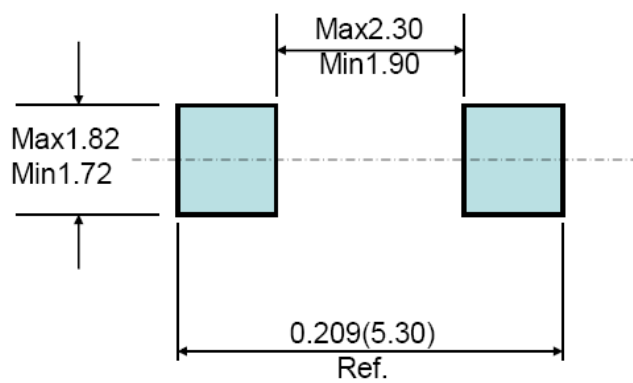

标题Title: 塑封生产线SMD产品包装规范 Packaging specification of SMD	文件编号: WI-258
	第 3 版 第 0 次修改
	第 2 页

SMD产品通用包装材料规格以及包装产品数量
General packaging materials spec. and quantity

1.1 卷装 reel

A. 卷盘规格 reel spec

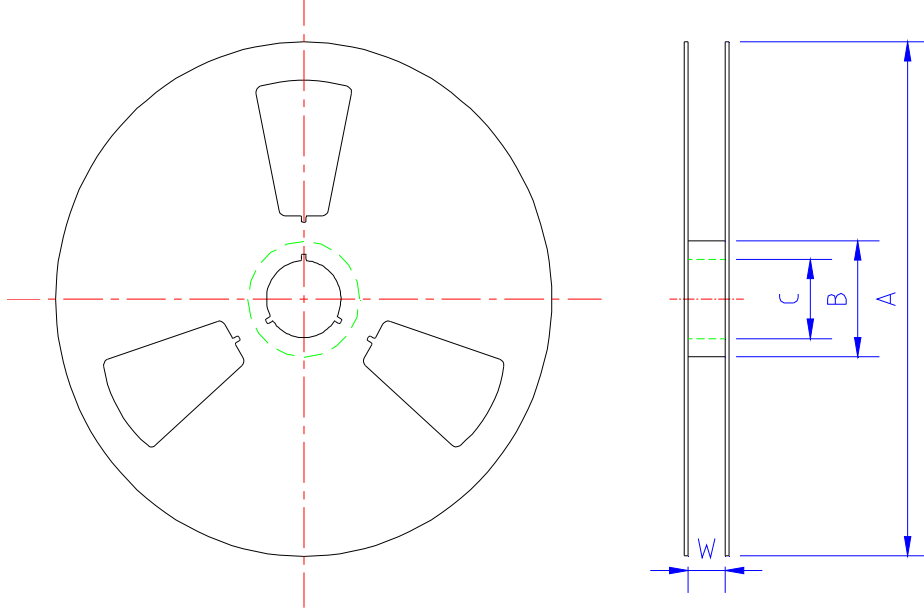

单位: mm

规格	A	B	C	W	每卷数量
SMA 7"卷盘	177.0±2.0	54.0±0.5	13.0±0.5	13.2±0.2	2K
SMA13"卷盘	330.0±2.0	75.0±0.5	13.0±0.5	13.2±0.2	5K
SMB13"卷盘	330.0±2.0	75.0±0.5	13.0±0.5	13.5±0.5	3K
SMC13"卷盘	330.0±2.0	75.0±0.5	13.0±0.5	17.0±0.5	3K

B. 13"卷盘内盒 inner box

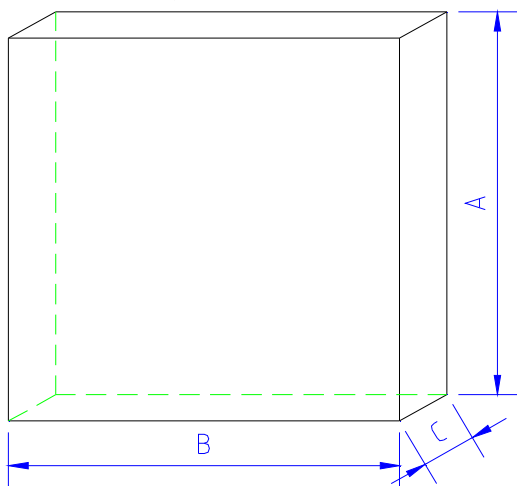

单位: mm

	A	B	C
尺寸	335±5.0	335±2.0	40±1.0

按以上包装方式, 产品包装数量: quantity

规格	每盒数量
SMA13"卷盘	10K
SMB13"卷盘	6K
SMC13"卷盘	6K

标题Title:

塑封生产线SMD产品包装规范
Packaging specification of SMD

文件编号: WI-258

文件编号: WI-258

第 3 页

C. 7"卷盘盒 box

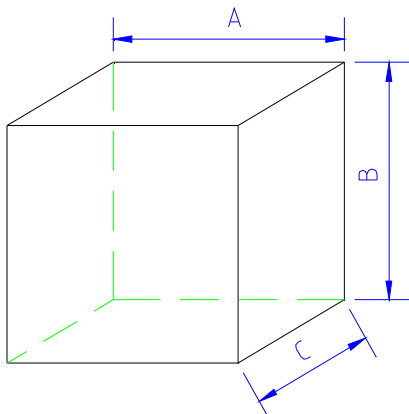

单位: mm

	A	B	C
尺寸	188±2.0	188±2.0	138±2.0

按以上包装方式, 产品包装数量: quantity

	每盒数量
7"卷盘	16K

D. 卷盘外箱 reel carton

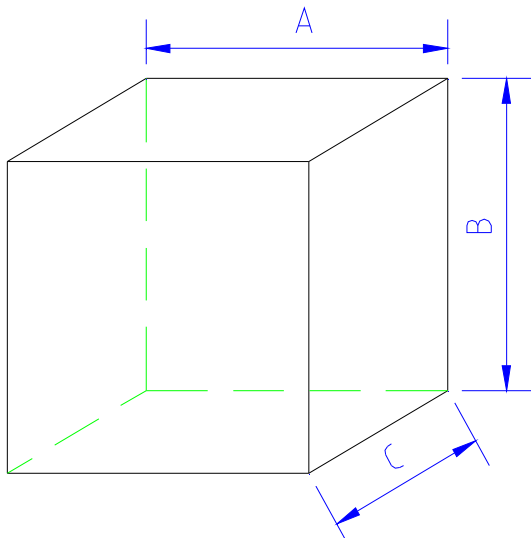

单位: mm

	A	B	C
尺寸	350±2.0	340±2.0	350±2.0

按以上包装方式, 产品包装数量:

规格	每箱数量
SMA 7"卷盘	80K
SMA13"卷盘	80K
SMB13"卷盘	48K
SMC13"卷盘	36K

1.2 编带规格 tape spec

A. 盖带 Cover tape

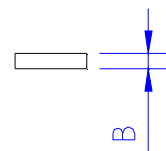

单位: mm

	A	B
SMA	9.30±0.10	0.068±0.005
SMB		
SMC		

标题Title:

塑封生产线SMD产品包装规范
Packaging specification of SMD

文件编号: WI-258

第 3 版 第 0 次修改

第 4 页

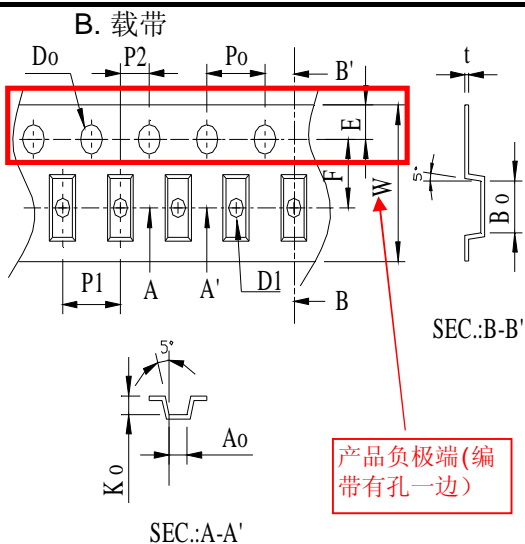

类型	SMA	SMB	SMC
W	12±0.3	12±0.3	16±0.3
P1	4±0.1	8±0.1	8±0.1
E	1.75±0.1	1.75±0.1	1.75±0.1
F	5.5±0.05	5.5±0.05	7.5±0.05
D0	1.55±0.05	1.55±0.05	1.55±0.05
D1	1.5±0.1	1.55±0.05	1.55±0.05
P0	4±0.1	4±0.1	4±0.1
P2	2±0.05	2±0.05	2±0.05
10P0	40±0.2	40±0.2	40±0.2
A0	2.79±0.1	3.8±0.1	6.05±0.1
B0	5.33±0.1	5.4±0.1	8.31±0.1
K0	2.36±0.1	2.45±0.1	2.54±0.1
T	0.25±0.05	0.25±0.05	0.25±0.05

2、SMD产品通用包装规范 General spec of SMD

5.2.1国内客户domestic

A. 7"卷盘reel

所有标签贴在卷盘负极 all the label on cathode side

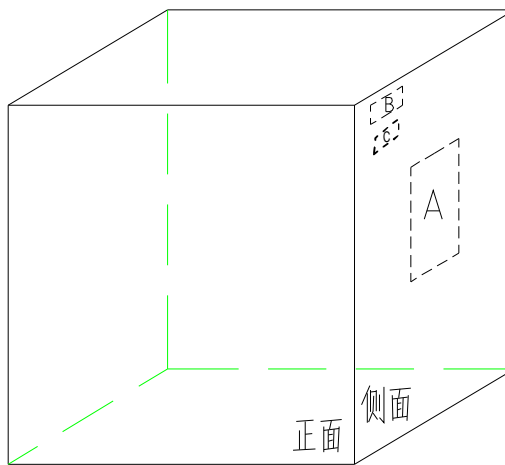
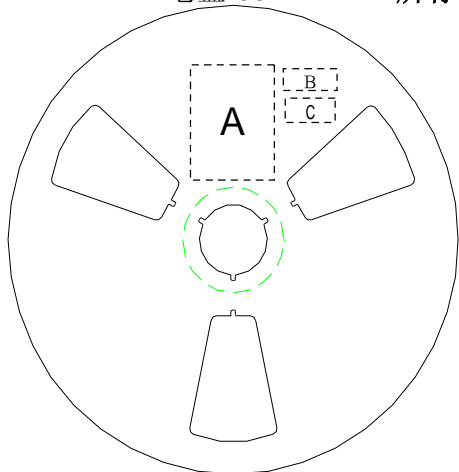

A处:贴LRC标签; B处:贴ROHS标签 C处:贴无卤标签 HF label

B. 13"卷盘

所有标签贴在卷盘负极 all the label (无卤产品才贴HF only)

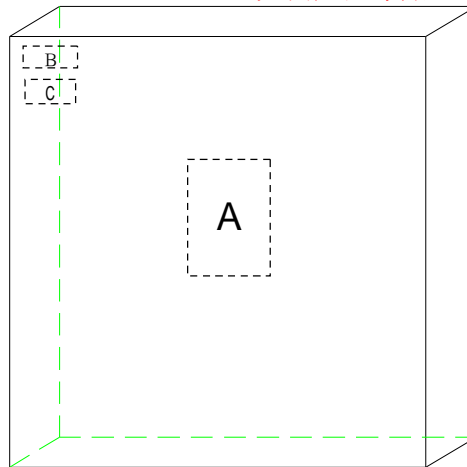
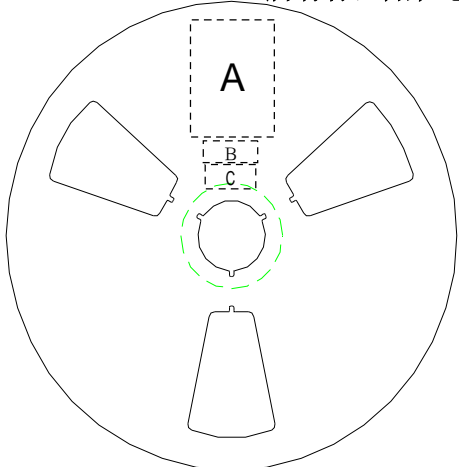

A处:贴LRC标签; B处:贴ROHS标签 C处:贴无卤标签 (无卤产品才贴HF only)

标题Title:

塑封生产线SMD产品包装规范
Packaging specification of SMD

文件编号: WI-258

第 3 版 第 0 次修改

第 5 页

C. 标签要求label spec:

LRC标签label

型号 TYPE	*****
数量(只) QTY(PCS)	*****
批号 LOT	*****
日期 DATE	*****
检验员: CHECKER	

LRC产品型号 type

产品数量 quantity

产品批号 LOT

产品生产日期 date

ROHS标签



无卤标签 HF label



2.2 国外客户
overseas

所有标签贴在卷盘负极 all the label on cathode side

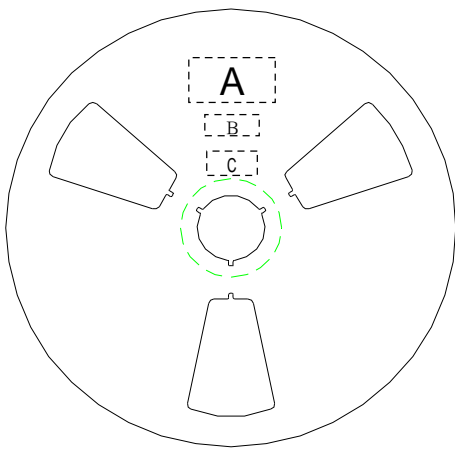

7"卷盘盒 inner box

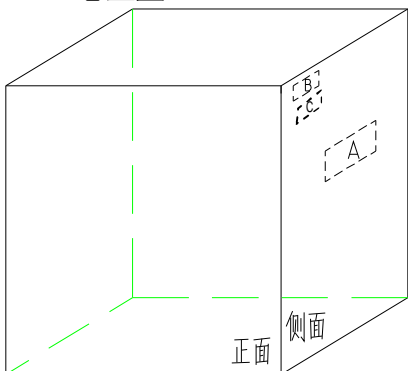

13"卷盘内盒inner box

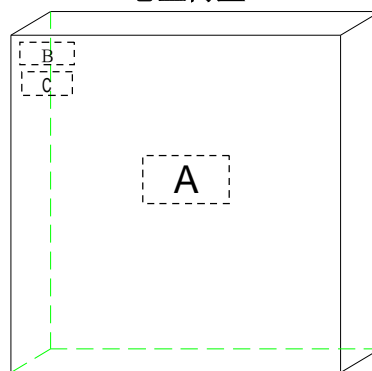

A处:贴LRC标签;

B处:贴ROHS标签

C处:贴无卤标签HF label
(无卤产品才贴HF only)

标题Title: 塑封生产线SMD产品包装规范 Packaging specification of SMD	文件编号: WI-258
	第 3 版 第 0 次修改
	第 6 页

LRC标签label

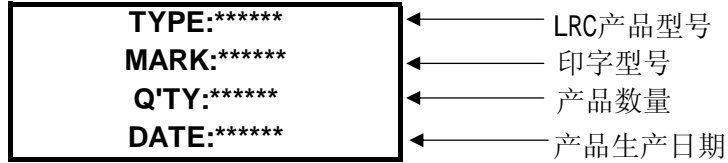

ROHS标签



无卤标签 HF label



注意事项NOTE:

1. 13"卷盘内盒装好产品,需用热缩膜包装;13"reel'inner box must be packed by shrink film
2. 所有编带产品卷装完成后,用白色胶带将编带粘牢;

every tape after packing, must be fixed by white adhesive tape

3.1产品出厂检验报告 testing report of the OQC

每批出货时, 需要附上出厂检验报告 every lot must with test report

3.2尾箱

同一编码每批次只允许出现一个尾数箱, 对于尾数物料, 须用缓冲材料对空余部分填充好, 保证物料在受到一定的外作用力下不发生明显移动, 且物料间无碰撞。

The same coding is only one ending for each batch box materials for the mantissa to be good filled with cushioning material.

SZA***A Series

5. Update Record

版次	更新记录	更新作者	更新日期
1	第一版	周杰	2010.12.28
2	增加产品型号	周杰	2011.03.28
3	增加产品型号	周杰	2012.02.09